



# SYNRAD Technical Bulletin

# 0011

Technical Issue: Replacing FH Smart with an FH Flyer Marking Head

Date: 22 August 2007

## Description:

This Technical Bulletin describes the steps involved when replacing an existing FH Series Smart marking head with a new FH Flyer head. There are several important differences, so please review this document or the *FH Series Flyer Operator's Manual* for details before proceeding.

This Bulletin covers the following topics:

- Mechanical
  - Mounting
  - Beam Position
- Electrical
  - I/O Voltage Levels
  - Flyer *User Interface* Connector (DB-25)
  - FH Smart to FH Flyer I/O conversion
  - Fast Acting Safety Interlock (FASI)
- Communications
  - USB
  - Ethernet
- Start-Up
- WinMark Pro v5
  - System Requirements
  - Installation
  - Mark File Adjustments



## Mechanical Mounting

Overall length of the Flyer head has increased by 0.070" due to the addition of a finned heat-sink. Dimensions are 8.45" L x 6.15" H x 5.40" W (including focusing lens mount).

## Beam Position

When mounted to an existing SYNRAD *L-bracket*, the center of Flyer's beam exit is located 0.10" away from the center of the FH Smart mark field in the -X direction (to the right, away from the L-bracket, when facing Flyer's membrane panel). If the FH Smart *L-bracket* is replaced with a Flyer *L-bracket* (SYNRAD part number 130-18113-02), the center of the mark field is identical; no offset of the part or mark file is required.

## Electrical I/O Voltage Levels

**Important Note:** The I/O voltage level for FH Flyer inputs is between 5 V and 24 VDC. Note that this range differs from the input voltage range of previous FH Series marking heads. If your existing equipment interface uses voltages above 24.0 VDC you must adapt your circuit or components to a voltage level of 5 V–24VDC.

## Flyer User Interface Connector (DB-25)

**! Caution:** The pin assignments on Flyer's DB-25 *User Interface* connection are **NOT** compatible with FH Smart's DB-25 *Parts Handling Control* connection. When integrating an FH Flyer head into an existing FH Smart marking system, you must revise any I/O field wiring connected to Flyer's DB-25 *User Interface* connector. Failure to do so may damage Flyer's internal circuitry and/or any external devices connected to the I/O wiring harness.

Table 1 lists pin assignments for Flyer's DB-25 *User Interface* connection.



**Table 1 User Interface pin assignments**

DB-25 Pin #	Signal Name	Signal Description
1	+ 15 V	Internal +15 VDC, 400 mA I/O power supply
2	OUT2–OUT7_B	*B connection point for OUT2 through OUT7
3	OUT6_A	*A connection point for OUT6
4	OUT4_A	*A connection point for OUT4
5	OUT2_A	*A connection point for OUT2
6	OUT1_A	*A connection point for OUT1
7	OUT0_A	*A connection point for OUT0
8	IN0_B	*B connection point for IN0
9	IN1_HI	**High (+V) connection point for IN1
10	IN2_HI	**High (+V) connection point for IN2
11	IN4_A	*A connection point for IN4
12	IN6_A	*A connection point for IN6
13	IN3–IN7_B	*B connection point for IN3 through IN7
14	+ 15 RTN	Return point for internal 15 VDC supply
15	OUT7_A	*A connection point for OUT7
16	OUT5_A	*A connection point for OUT5
17	OUT3_A	*A connection point for OUT3
18	OUT1_B	*B connection point for OUT1
19	OUT0_B	*B connection point for OUT0
20	IN0_A	*A connection point for IN0
21	IN1_LO	**Low (–V) connection point for IN1
22	IN2_LO	**Low (–V) connection point for IN2
23	IN3_A	*A connection point for IN3
24	IN5_A	*A connection point for IN5
25	IN7_A	*A connection point for IN7

\*Bidirectional inputs and outputs are not polarity sensitive—you can connect “A” and “B” connection points to either the low side (– VDC or ground) or high side (+ VDC) of your I/O circuit.

\*\* High-speed (encoder) inputs IN1 and IN2 are polarity sensitive. Connect the high, or positive, side (+ VDC) to the HI connection point. Connect the low, or ground, side (– VDC) to the LO connection point.

Figure 1 shows the physical layout of FH Flyer's *User Interface* connection.

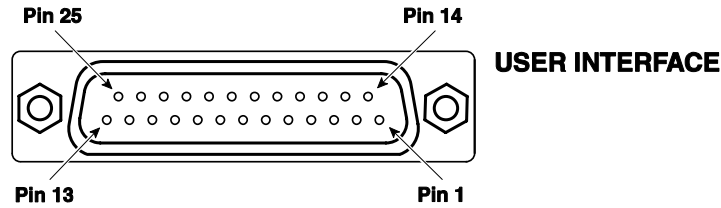

**Figure 1 Physical layout of Flyer's User Interface connection**

### Internal +15 VDC supply

An internal 15-volt (+15 VDC, 400 mA) isolated power supply is available to drive FH Flyer inputs or outputs in lieu of a customer-supplied power source. When powering input/output devices or tracking components such as part sensor and position encoder hardware, remember that the total current demand of these devices cannot exceed 400 mA. On Flyer's *User Interface* connection, Pin 1 is +15 VDC while Pin 14 is the isolated return side of the supply. Table 2 summarizes +15 VDC pin assignments.

**Table 2 +15 VDC pin assignments**

DB-25 Pin #	Signal Name	Signal Description
1	+ 15 V	Internal +15 VDC, 400 mA I/O power supply
14	+ 15 RTN	Return point for internal 15 VDC supply

## Digital input circuitry

**Important Note:** The I/O voltage level for FH Flyer inputs is between 5 V and 24 VDC. Note that this range differs from the input voltage range of previous FH Series marking heads. If your existing equipment interface uses voltages above 24.0 VDC you must adapt your circuit or components to a voltage level of 5 V–24VDC.

FH Flyer provides eight optoisolated inputs, IN0–IN7, for connecting to external input devices including part sensors, position encoders, relays, and Programmable Logic Controller (PLC) DC output modules. Table 3 summarizes input pin assignments.

**Table 3 Input pin assignments**

DB-25 Pin #	Signal Name	Signal Description	Typical Use
20	IN0_A	*A connection point for IN0	Part sense signal
8	IN0_B	*B connection point for IN0	
9	IN1_HI	**High (+V) connection point for IN1	High-speed input
21	IN1_LO	**Low (–V) connection point for IN1	
10	IN2_HI	**High (+V) connection point for IN2	High-speed input
22	IN2_LO	**Low (–V) connection point for IN2	
23	IN3_A	*A connection point for IN3	Any
11	IN4_A	*A connection point for IN4	Any
24	IN5_A	*A connection point for IN5	Any
12	IN6_A	*A connection point for IN6	Any
25	IN7_A	*A connection point for IN7	Any
13	IN3–IN7_B	*B connection point for IN3 through IN7	

\*Bipolar inputs are not polarity sensitive—you can connect “A” and “B” connection points to either the low side (– VDC or ground) or high side (+ VDC) of your I/O circuit.

\*\* High-speed (encoder) inputs IN1 and IN2 are polarity sensitive. Connect the high, or positive, side (+ VDC) to the HI connection point. Connect the low, or ground, side (– VDC) to the LO connection point.

Inputs IN1\_HI and IN2\_HI are high-speed optoisolated inputs with a maximum input frequency of 40 kHz and are the required inputs when connecting a position encoder for tracking purposes. These inputs are unipolar where IN1\_HI and IN2\_HI always connect to the high (+V) side of the input circuit while IN1\_LOW and IN2\_LOW provide the corresponding isolated low side return. Refer to Table 4 for IN1/IN2 input specifications.

When driving Flyer’s high-speed encoder inputs, IN1 and IN2, your signal device must be capable of providing the maximum current value shown in Table 4 at the appropriate input voltage. IN1/IN2 input lines are protected by 100 mA self-resetting fuses.

**Table 4 FH Flyer input signal parameters—IN1/IN2**

Input #	Voltage In (VDC)		Current In, max (mA)				Frequency, max (kHz)
	Logic Low	Logic High	@5V	@12V	@15V	@24V	
IN1/IN2	-0.6 to +1.7	+5.0 to 24.0	9	32	47	90	40

The other six bipolar optoisolated inputs, IN0 and IN3–IN7, have a maximum input frequency of 1 kHz. IN0, which normally serves as the part sensor or ‘start mark’ input, has an isolated return line. Inputs IN3 through IN7 share a common return line that allows the user to configure either high-side switching on all five inputs or low-side switching on all five inputs. Refer to Table 5 for IN0 and IN3–IN7 input specifications. When driving Flyer inputs IN0 and IN3 through IN7, your signal device must be capable of providing the maximum current value shown in Table 5 at the appropriate input voltage. Inputs IN0 and IN3–IN7 are protected by 50 mA self-resetting fuses.

**Table 5 FH Flyer input signal parameters—IN0, IN3–IN7**

Input #	Voltage In (VDC)		Current In, max (mA)				Frequency, max (kHz)
	Logic Low	Logic High	@5V	@12V	@15V	@24V	
IN0, IN3–IN7	-1.0 to +1.0	+3.0 to 24.0	9	23	29	47	1

**Input field wiring notes**

In electrically noisy environments, we recommend using shielded, multi-conductor I/O cable as well as a shielded backshell when connecting field wiring to Flyer’s DB-25 *User Interface* connector.

To minimize ground loop noise, ground the cable shield at the signal source only. The cable shield at the *User Interface* connector must be left floating unless you are using Flyer’s +15 VDC auxiliary power output as the I/O signal source.



### Digital output circuitry

FH Flyer provides eight bipolar optoisolated outputs, OUT0–OUT7, for operating low-current relays or Programmable Logic Controller (PLC) DC input modules or other parts handling automation devices. Two outputs, OUT0 and OUT1, have isolated return pins that allow them to function independently as high-side (current sourcing) or low-side (current sinking) switches. The remaining six outputs, OUT2–OUT7, share a common return line that allows the user to configure all six outputs as either high-side switches or low-side switches. Table 6 summarizes output pin assignments while Table 7 shows output signal specifications. FH Flyer outputs are able to sink or source 30 mA maximum.

**Table 6 Output pin assignments**

DB-25 Pin #	Signal Name	Signal Description	Typical Use
7	OUT0_A	*A connection point for OUT0	Any
19	OUT0_B	*B connection point for OUT0	
6	OUT1_A	*A connection point for OUT1	Any
18	OUT1_B	*B connection point for OUT1	
5	OUT2_A	**A connection point for OUT2	Any
17	OUT3_A	**A connection point for OUT3	Any
4	OUT4_A	**A connection point for OUT4	Any
16	OUT5_A	**A connection point for OUT5	Any
3	OUT6_A	**A connection point for OUT6	Any
15	OUT7_A	**A connection point for OUT7	Any
2	OUT2– OUT7_B	**B connection point for OUT2 through OUT7	

\*Bipolar outputs are not polarity sensitive—you can connect “A” and “B” connection points to either the low side (– VDC or ground) or high side (+ VDC) of your I/O circuit.

\*\*Bipolar outputs are not polarity sensitive—you can connect “A” and “B” connection points to either the low side (– VDC or ground) or high side (+ VDC) of your I/O circuit; however, OUT2–OUT7 share a common return point so outputs OUT2–OUT7 must all connect to either the low side (– VDC or ground) or high side (+ VDC) — they cannot be mixed.



**Table 7 FH Flyer output signal parameters**

<b>Output Parameter</b>	<b>Specification</b>
Sinking / Sourcing Current, max.	30 mA
Maximum Load Voltage	26 VDC
Output Impedance (On state)	~900 Ohms
Turn-On Time, max.	3.0 ms
Turn-Off Time, max.	0.2 ms
Off State Leakage Current, max.	1.0 $\mu$ A

### FH Smart to FH Flyer I/O Conversion

In order to retrofit a Flyer head into an existing FH Smart application, you must make changes to your physical field wiring. Refer to input circuit and output circuit conversion sections for specific details. Table 8 lists pin-to-pin connections for converting the FH Smart DB-25 *Parts Handling Control* connector to Flyer's DB-25 *User Interface* connector.

**Important Note:** The I/O voltage level for FH Flyer inputs is between 5 V and 24 VDC. Note that this range differs from the input voltage range of previous FH Series marking heads. If your existing equipment interface uses voltages above 24.0 VDC you must adapt your circuit or components to a voltage level of 5 V–24VDC.





**Table 8 FH Smart to FH Flyer I/O conversion**

FH Smart DB-25 I/O Connector		Flyer DB-25 I/O Connector	
Pin #	Function	Pin #	Function
1	+15 V	1	+ 15 V
2	IN7	25	IN7_A
3	IN6	12	IN6_A
4	IN5	24	IN5_A
5	IN4	11	IN4_A
6	IN3	23	IN3_A
7	IN2	10	IN2_HI
8	IN1	9	IN1_HI
9	IN0	20	IN0_A
10	OUT6/OUT7 RTN	**2	OUT2-OUT7_B
11	OUT5	16	OUT5_A
12	OUT4	4	OUT4_A
13	DO NOT CONNECT	—	— —
14	+ 15 RTN / IN7 RTN*	14	+ 15 V RTN*
15	IN6 RTN	13	IN3-IN7_B
16	IN5 RTN	13	IN3-IN7_B
17	IN4 RTN	13	IN3-IN7_B
18	IN3 RTN	13	IN3-IN7_B
19	IN2 RTN	22	IN2_LO
20	IN1 RTN	21	IN1_LO
21	IN0 RTN	8	IN0_B
22	OUT7	15	OUT7_A
23	OUT6	3	OUT6_A
24	OUT4/OUT5 RTN	**2	OUT2-OUT7_B
25	DO NOT CONNECT	—	— —

\* If your existing FH Smart head has the return (ground) from input IN7 (IN7 RTN) wired to Pin 14, you must move this input return connection to Pin 13, IN3-IN7\_B, on the FH Flyer marking head.

\*\*On the Flyer DB-25 *User Interface* connector, outputs OUT2-OUT7 share a common return—OUT2-7\_B on Pin 2. This wiring scheme assumes that OUT4/OUT5 RTN and OUT6/OUT7 RTN are all tied to the DC supply's ground (return) side.



Input circuit conversion

Table 9 shows pin to pin connections for converting existing FH Smart input signals to Flyer's DB-25 *User Interface* connector.

**Table 9 FH Smart input conversion**

FH Smart DB-25 I/O Connector		Flyer DB-25 I/O Connector	
Pin #	Function	Pin #	Function
2	IN7	25	IN7_A
3	IN6	12	IN6_A
4	IN5	24	IN5_A
5	IN4	11	IN4_A
6	IN3	23	IN3_A
7	IN2	10	IN2_HI
8	IN1	9	IN1_HI
9	IN0	20	IN0_A
14	IN7 RTN*	13	IN3-IN7_B
15	IN6 RTN	13	IN3-IN7_B
16	IN5 RTN	13	IN3-IN7_B
17	IN4 RTN	13	IN3-IN7_B
18	IN3 RTN	13	IN3-IN7_B
19	IN2 RTN	22	IN2_LO
20	IN1 RTN	21	IN1_LO
21	IN0 RTN	8	IN0_B

\* If your existing FH Smart head has the return (ground) from input IN7 (IN7 RTN) wired to Pin 14, you must move this input return connection to Pin 13, IN3-IN7\_B, on the FH Flyer marking head.

Output circuit conversion

Tables 10 and 11 show pin to pin connections for converting existing FH Smart output signals to Flyer's DB-25 *User Interface* connector. Use Table 10 when all return lines (RTN4-RTN7) are connected to the I/O circuit's DC ground or return (FH Smart outputs function as low-side switches and are sinking current).

**Table 10 FH Smart output conversion—all RTN lines grounded (sinking current)**

FH Smart DB-25 I/O Connector		Flyer DB-25 I/O Connector	
Pin #	Function	Pin #	Function
10	OUT6/OUT7 RTN	*2	OUT2-OUT7_B
11	OUT5	16	OUT5_A
12	OUT4	4	OUT4_A
22	OUT7	15	OUT7_A
23	OUT6	3	OUT6_A
24	OUT4/OUT5 RTN	*2	OUT2-OUT7_B

\*On the Flyer DB-25 *User Interface* connector, outputs OUT2-OUT7 share a common return—OUT2-7\_B on Pin 2. This wiring scheme assumes that OUT4/OUT5 RTN and OUT6/OUT7 RTN are both tied to the I/O supply's DC ground or return side (FH Smart outputs are sinking current).

Refer to Table 11 when all output lines (OUT4-OUT7) are connected to the I/O circuit's DC voltage supply (V+) (FH Smart outputs function as high-side switches and are sourcing current).

**Table 11 FH Smart output conversion—all OUT lines tied to V+ (sourcing current)**

FH Smart DB-25 I/O Connector		Flyer DB-25 I/O Connector	
Pin #	Function	Pin #	Function
10	OUT6/OUT7 RTN	3	OUT6_A
12	OUT4	*2	OUT2-OUT7_B
23	OUT6	*2	OUT2-OUT7_B
24	OUT4/OUT5 RTN	4	OUT4_A

\*On the Flyer DB-25 *User Interface* connector, outputs OUT2-OUT7 share a common return—OUT2-7\_B on Pin 2. Because FH Smart OUT4/OUT5 and OUT6/OUT7 share common returns, only two outputs (OUT4 and OUT6) can be used in this current sourcing configuration. This wiring scheme assumes that FH Smart outputs OUT4-OUT7 are all tied to the I/O supply's positive DC (V+) voltage (FH outputs are sourcing current).

If four or more outputs are required in a current sourcing arrangement (FH Flyer offers a total of eight outputs—two with isolated return lines, the other six share a common return), then rewire your Smart output circuitry to take advantage of this functionality. See Table 6, FH Flyer output pin assignments, for details.

## FASI

To set the Fast Acting Safety Interlock (FASI) for an FH Flyer head, refer to the directions below. Note that WinMark Pro v5 shows the current FASI state (*FASI Enable*) on the Tools / General Settings... / "Flyer" tab (see Figure 2). If you have previously named your Flyer head, this tab name will display Flyer's current "device name".

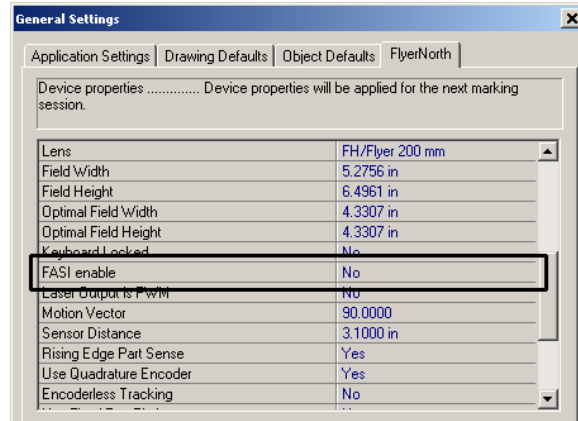

**Figure 2 Current FASI state displayed in WinMark**

- 1 Remove DC power from the Flyer head or disconnect the *DC Power* cable.
- 2 Refer to Figure 3 and withdraw two button head Allen screws and two Allen head capscrews at the locations shown to remove Flyer's upper cover.

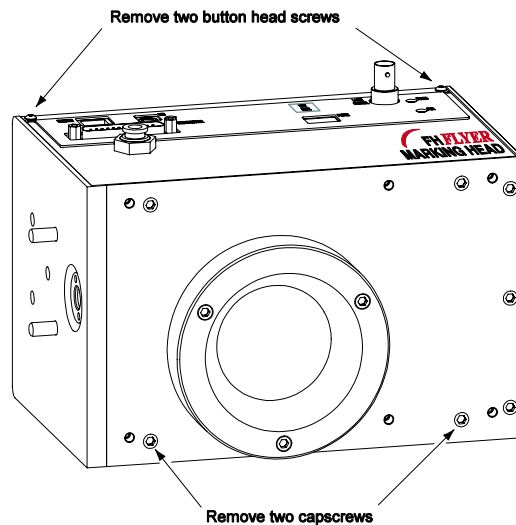

**Figure 3 Opening Flyer to enable FASI**

- 3 Carefully remove Flyer's upper cover and place to one side.
- 4 Ground yourself by keeping one hand in constant contact with Flyer's lower metal cover.
- 5 Locate the DIP switch bank labeled SW1 on the CPU board (see Figure 4) and move switch # 1 to the "ON" position.

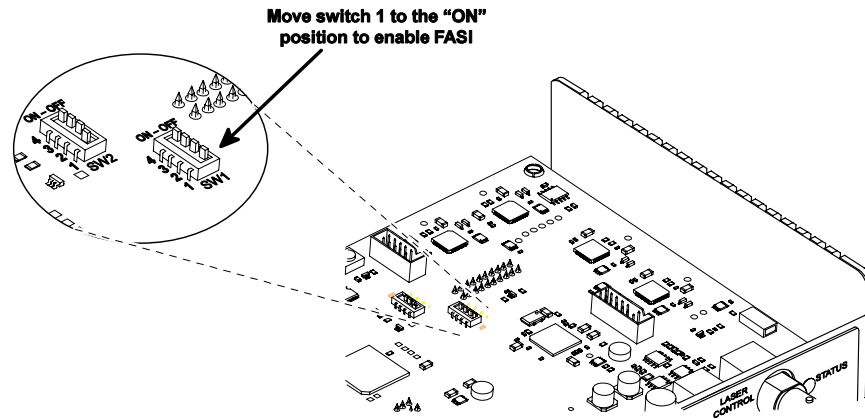

**Figure 4 Flyer DIP switch locations**

- 6 Do not change any other DIP switch settings; all switches must remain at their default settings!
- 7 Carefully replace Flyer's upper cover and tighten the screws removed in Step 1. Ensure that no cables are pinched or disturbed as the cover is replaced.
- 8 To enable lasing with FASI switched "On", apply a 5 V–24 VDC signal to Flyer input IN3.

When FASI is enabled, IN3 must be active before the laser will fire. If the FASI feature is enabled but IN3 is inactive (no current flow), then no marking will occur. In FASI mode, even manual firing of the laser using the *Test Mark* pushbutton requires an active input signal on IN3.

## Communications

### USB

FH Flyer communicates to WinMark Pro v5 through a USB or Ethernet port connection; there is no provision for a fiber optic interface. Even when an Ethernet connection is the desired communication mode, you must perform Flyer's initial Ethernet configuration using the USB port.

FH Series Flyer incorporates a USB (Universal Serial Bus) connection between the host and the head. This connection provides communication between WinMark Pro and the Flyer head when marking, testing, or configuring Flyer's Ethernet port. Flyer heads support USB V2.0 Full Speed connections with a data bandwidth of 12 million bits per second (Mbps).

The *USB* indicator next to the *USB* port on Flyer illuminates green when Flyer and the computer are both powered up and connected via the *USB Communication* cable. The LED turns red when WinMark Pro is communicating with Flyer.

Included in the Flyer ship kit is a six-foot (1.8 m) long *USB Communication* cable. The cable end with the flat USB "A" plug connects into the host system (one of your computer's USB ports) while the square USB "B" plug connects into Flyer's *USB* port. If a longer cable is required, SYNRAD highly recommends buying a USB extension cable. Please note that the USB specification does not permit an overall USB cable length longer than 16.4 feet (5.0 m).

**Note:** When supplying your own USB cable, please ensure that it is double-shielded. This prevents electrical noise in industrial environments from interfering with communications between your computer and the Flyer head.

To connect the USB cable, perform the following steps:

- 1 Locate the *USB Communication* cable in the ship kit. This double-shielded cable is approximately 6 feet (1.8 m) long with a USB "A" plug on one end and a USB "B" plug on the other.
- 2 Plug the USB "A" plug (the flat rectangular end) into one of the USB "A" ports on your computer.
- 3 Plug the USB "B" plug (the square end) into the *USB* port on the side of the Flyer head.

It is not necessary to power down Flyer or your computer when connecting or disconnecting the *USB Communication* cable; USB protocol allows the ability to "hot plug" or unplug devices.

## Ethernet

After the development phase is complete and your Flyer head is placed in a production environment you may find that Flyer's Ethernet connectivity provides a better method of communicating with multiple heads in a networked environment.



Before connecting to Flyer through an Ethernet connection, you must first configure Flyer's Ethernet port. To setup Flyer's initial Ethernet configuration, perform the following steps:

**Important Note:** When both USB and Ethernet cables are connected, the USB port takes precedence over the Ethernet port for control purposes.

**Note:** The setup procedure described below may require the assistance of your IT Department because Flyer's Ethernet settings are determined solely by your facility's computer network.

- 1 Ensure that the proper Ethernet cable is connected between Flyer and the host computer. Your IT Department will determine if you require a straight-thru or crossover cable. For additional cabling information, see the *Ethernet port* section in the Technical Reference chapter of the *FH Series Flyer Operator's Manual*.
- 2 Connect the *USB Communication* cable between Flyer and the WinMark Pro host computer.
- 3 Power up Flyer and then open WinMark Pro v5. On the *Tools* menu, select *General Settings...*, and then click the "*Flyerxxxxx*" tab.
- 4 If your computer network uses Dynamic Host Configuration Protocol (DHCP), then locate the *Use DHCP* property and set it to *Yes*. When *Use DHCP* is *Yes*, Flyer will automatically query your DHCP server for a valid IP address and other network parameters.

**Note:** We recommend you do not use DHCP. Under the DHCP scheme, Flyer's IP address and DNS name will change each time the head is turned off for a time period that exceeds the DHCP lease.

- 5 If your facility does not use DHCP, set the *Use DHCP* property to *No*. Consult your IT Department and manually enter values for the following properties: *Ethernet IP Address or Host Name*, *IP Netmask*, *IP Gateway*, and *DNS Server IP Address*. If required, you may enter two different DNS server IP addresses.
- 6 Click *OK* and remove power from the Flyer head.
- 7 Disconnect the *USB Communication* cable from the head and re-apply DC power. Upon start-up, Flyer will communicate via Ethernet using the protocol you have selected.



## Start-Up

Applying power to Flyer begins a 25–30 second boot-up sequence. During this time, the *Status* LED blinks green at a slow (2 Hz) rate. A solid green Status LED indicates that Flyer is ready for operation. When WinMark Pro v5 is opened, and the USB cable is connected between Flyer and the host, Flyer's *USB* LED illuminates red to indicate that communication is established.

## WinMark Pro v5

When operating an FH Flyer head, you must use WinMark Pro v5.

## System Requirements

WinMark Pro v5 Laser Marking Software requires the following minimum requirements:

- Windows® Vista, Windows® XP, or Windows® 2000 Operating System
- 16-MB RAM
- 30-MB Available Hard Drive Space
- CD-ROM Drive
- Two Open USB Ports

## Installation

To install WinMark Pro v5, uninstall your previous WinMark build and then double-click the WinMark\_Setup.exe file. Follow the instructions in the dialog boxes. If you wish to retain existing mark file defaults, select the *Keep Current Program Settings* option button in the *Save Current Synrad WinMark Registry Settings* dialog, otherwise select *Perform Clean Install*.

## Mark File Adjustments

### Object Delays

Because Flyer's optical scanners exhibit a much quicker response time than previous FH Series marking heads, you will need to adjust marking delays in existing mark files. If you have performed a clean install, recommended delay values will appear on the *Marking* tab. As a starting point, use the values below to obtain the best quality marks. Some experimentation may be required to optimize mark quality.

<i>Pline Start Delay</i>	—	0 $\mu$ s
<i>Pline End Delay</i>	—	200 $\mu$ s
<i>Interseg Delay</i>	—	75 $\mu$ s
<i>Off Vector Delay</i>	—	250 $\mu$ s
<i>Off Vector Velocity</i>	—	200 in/sec





### Drawing Automation

If your pre-existing output wiring was changed to accommodate Flyer's common return scheme for OUT2 through OUT7 (OUT2-7\_B on Pin 2), then modify your mark file automation as required.

For further information contact SYNRAD at 1.800.796.7231; outside the U.S., dial +1.425.349.3500 or fax us at +1.425.349.3667.