

4

3

2

1

NOTES:

- 1. MANUFACTURE IN ACCORDANCE WITH SYNRAD DOCUMENT "WORKMANSHIP STANDARD".
- 2. REFERENCE SURFACE FOR WORKING DISTANCE MEASUREMENTS.

REV	ECO	DATE	DESCRIPTION	DB
R1	.	21-Feb-14	INITIAL DESIGN	DMD
.	.	.	.	.
.	.	.	.	.

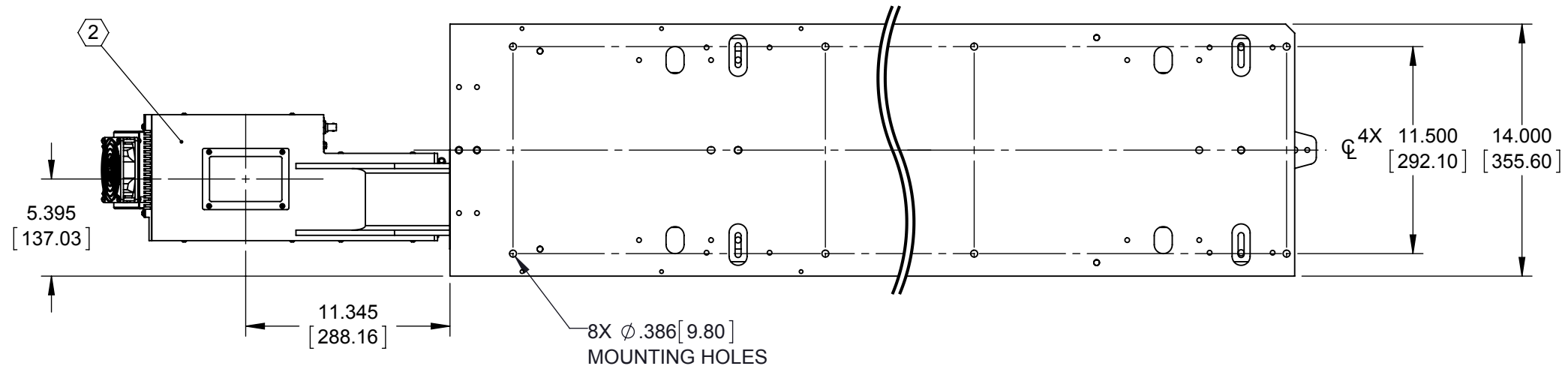
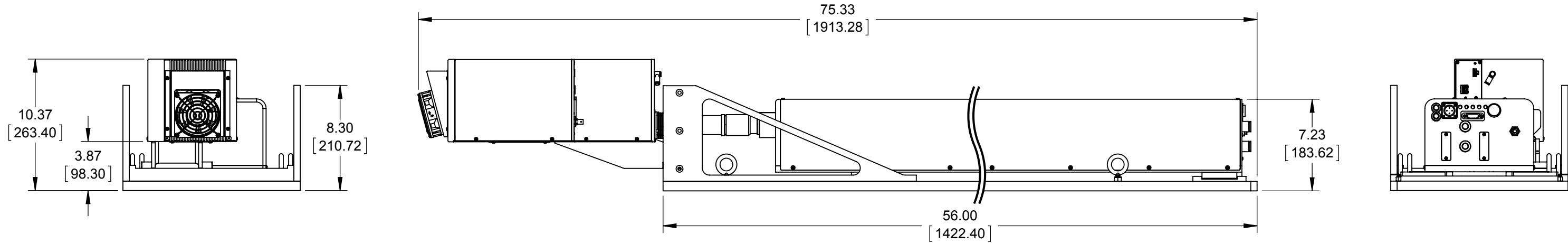

TOLERANCES UNLESS NOTED:		PROPRIETARY THIS DRAWING IS PROPRIETARY TO SYNRAD INC. AND SHALL NOT BE USED OR DISCLOSED IN WHOLE OR IN PART WITHOUT WRITTEN PERMISSION OF SYNRAD INC.		SYNRAD INC. 4600 Campus Place Mukilteo, WA 98275 Phone: (425)349-3500 Fax: (425)349-3667	
.x = ± .1		ANGLE = ± .5°		DESCRIPTION: <b>OUTLINE &amp; MOUNTING, FLYER 3D/F201</b>	
.xx = ± .01					
.xxx = ± .005					
MATERIAL:		PART NUMBER: 300-20818-06		DWG/FILE NUMBER: 300-20818-06	
FINISH:		SHEET 1 of 1		ENG: .	
		UNITS: Inches		DRAWN BY: D. DUVAL	
		SIZE: B		DATE: 21-Feb-14	
		FINISH CLASS: .		CHECKED BY:	
				DATE:	
				APPROVED BY:	
				DATE:	
				REV. R1	

4

3

2

1