

4

3

2

1

NOTES:

- 1. MANUFACTURE IN ACCORDANCE WITH SYNRAD DOCUMENT "WORKMANSHIP STANDARD".
- 2. REFERENCE SURFACE FOR WORKING DISTANCE MEASUREMENTS.

REV	ECO	DATE	DESCRIPTION	DB
R1	.	21-Feb-14	INITIAL DESIGN	DMD
.
.

B

B

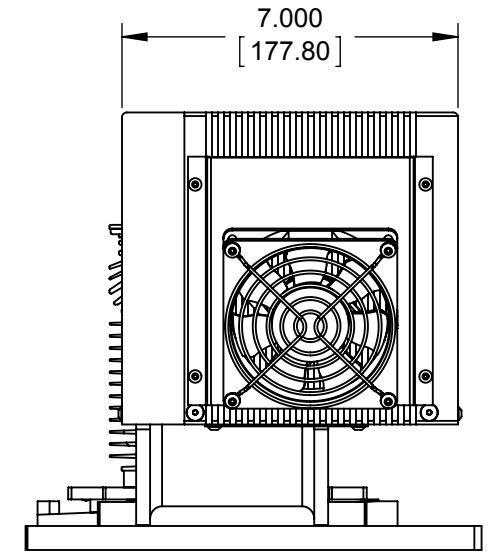
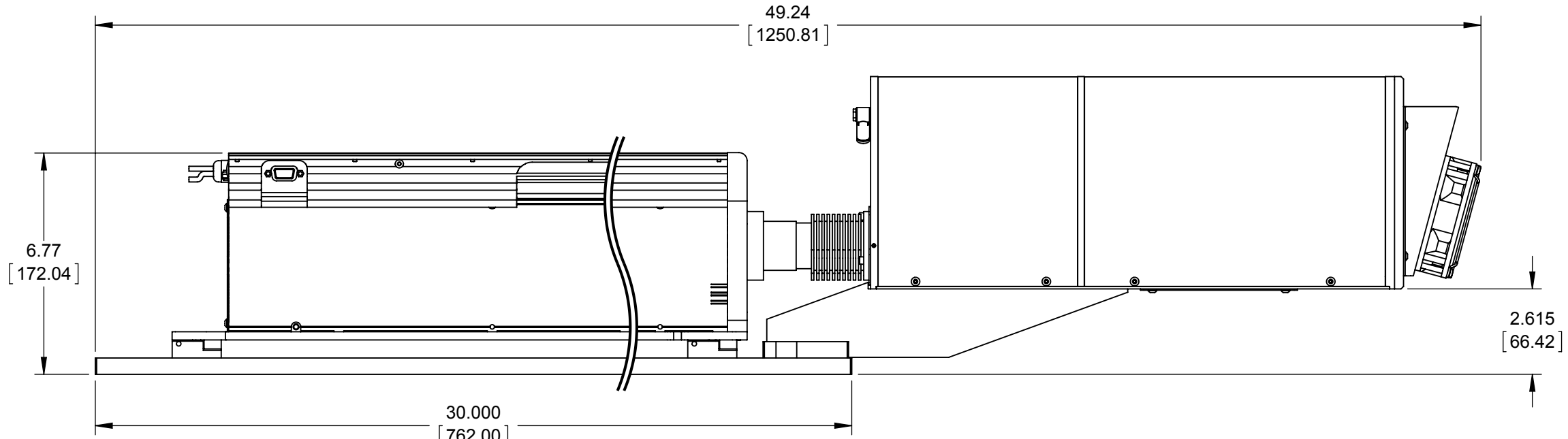

A

A

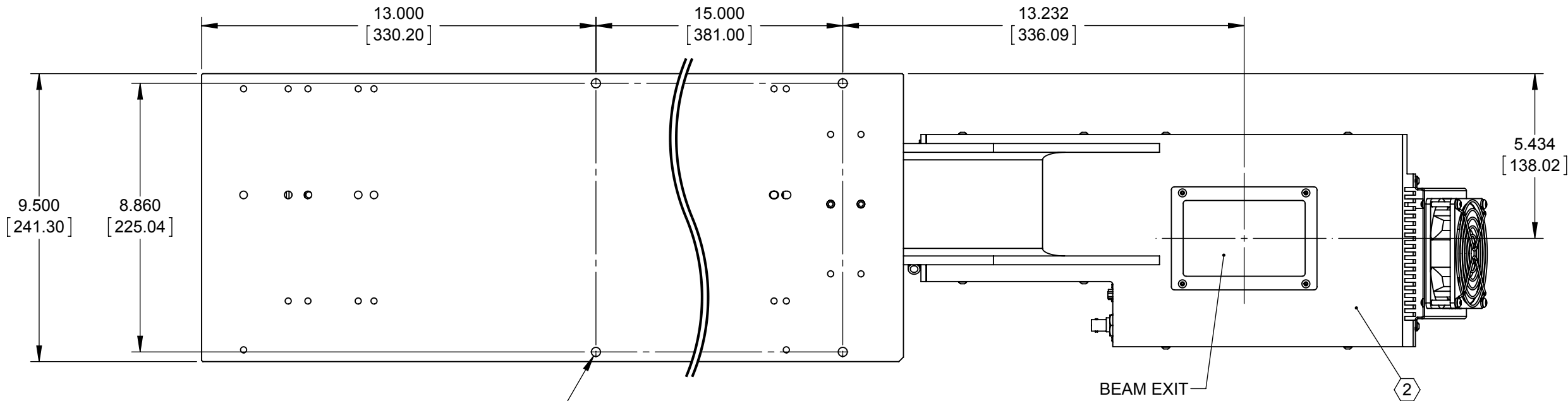

4X ϕ .300 [7.62]
MOUNTING HOLES

TOLERANCES UNLESS NOTED:

.x = ± .1	ANGLE = ± .5°
.xx = ± .01	
.xxx = ± .005	

MATERIAL:

FINISH:

PROPRIETARY
THIS DRAWING IS PROPRIETARY TO
SYNRAD INC. AND SHALL NOT BE
USED OR DISCLOSED IN WHOLE
OR IN PART WITHOUT WRITTEN
PERMISSION OF SYNRAD INC.



SYNRAD INC.
4600 Campus Place
Mukilteo, WA 98275
Phone: (425)349-3500
Fax: (425)349-3667

DESCRIPTION: OUTINE & MOUNTING, FLYER3D/V40			
PART NUMBER: 300-20818-03		DWG/FILE NUMBER: 300-20818-03	
SHEET 1 of 1	ENG: .	DRAWN BY: D. DUVALL	DATE: 21-Feb-14
UNITS: Inches	CATEGORY: .	CHECKED BY:	DATE:
SIZE: B	FINISH CLASS: .	APPROVED BY:	DATE:
			REV. R1

4

3

2

1