

# p150 CO<sub>2</sub> Laser

Industrial pulsed laser with more than 600 Watts of peak power for precision marking, drilling, and cutting applications



High performance pulsed CO<sub>2</sub> laser engineered for optimal power stability, excellent beam quality, and fastest pulse rise time, delivers exceptional quality on the most challenging materials

- 150 W of average power for faster throughput and higher yields across a variety of target materials
- 600 W peak power delivers energy more efficiently, minimizing heat affected zone (HAZ) to process sensitive materials
- Excellent power and divergence stability deliver consistent, high quality application results
- Integrated beam conditioning guarantees a high quality, circular output beam for precise cutting, drilling, and intricate feature details



Cutting Electronic Films



Cutting & Perforating Packaging Films & Foils

## Specifications

Output Specifications			
Wavelength	9.3 μm	10.2 μm	10.6 μm
Average Output Power <sup>1</sup>	>150 W		
Peak Pulse Power (typical) <sup>2</sup>	600 W	550 W	600 W
Peak Pulse Energy (maximum) <sup>3</sup>	335 mJ		
Power Stability (cold start) <sup>4</sup>	±5%	±6%	
Power Stability (typical, after 3 min.)	±3%		
Beam Quality (M <sup>2</sup> )	<1.2		
Beam Diameter <sup>5</sup>	8.5 mm ± 1.0 mm		
Divergence (full angle)	1.9 mrad ± 0.4 mrad		
Ellipticity	<1.2		
Polarization	Linear (Vertical)		
Rise/Fall Time <sup>6</sup>	<50 μs / <100 μs		
Operating Frequency	0 - 200 kHz		
Duty Cycle Range	≤37.5%		
Maximum Pulse Length	600 μs		
Power Supply			
DC Input Voltage	48 VDC		
Maximum Current	65 A		
Pulsed Current	100 A for < 700 μs		
Cooling			
Maximum Heat Load	3500 W		
Coolant Temperature	18 - 22° C (water)		
Minimum Flow Rate	2.0 GPM, <60 PSI		
Environmental			
Operating Ambient Temperature	15 - 40° C		
Maximum Humidity	95%, non-condensing		
Physical			
Dimensions (LxWxH) mm (inches)	798 x 132 x 155 (31.4 x 5.2 x 6.1)		
Weight	18.1 kg (40.0 lbs.)		

## When Results Matter

The p150 was designed in response to industry needs for very high quality results on difficult to process materials. The combination of fast pulse rise time, best-in-class 600 watts peak power, and excellent beam quality opens up new capabilities to process sensitive materials such as thin films, where melt lips can be greatly reduced and even eliminated.



1 - Power level guaranteed for 2 years from date of shipment, regardless of operation hours, within recommended coolant flow rate and temperature range.

2 - Measured at 1 kHz, 10% duty cycle

3 - Measured from average power at 625 Hz, 37.5% duty cycle.

4 - Measured as  $\pm(P_{max} - P_{min}) / (P_{max} + P_{min})$  from cold start at 5 kHz, 37.5% duty cycle.

5 - Measured 1/e<sup>2</sup> diameter at laser output

6 - Measured at 1 kHz, 10% duty cycle.

Specifications are subject to change without notice.

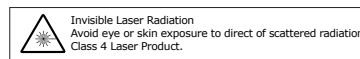

# p150 CO<sub>2</sub> Laser

Outline and Mounting Illustrations dimensions are in mm (inches)

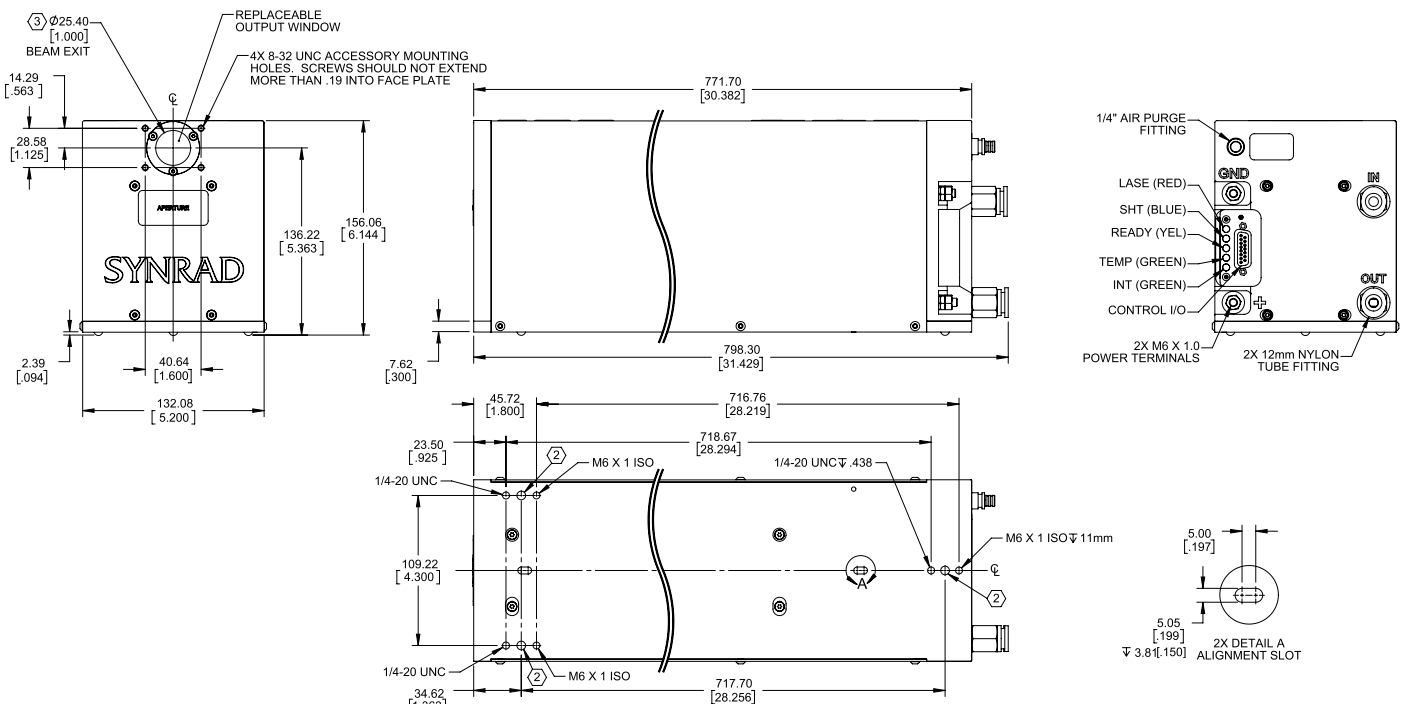

## Recommended Applications



### Cutting

150 W of continuous output power drives faster throughput for higher production yields. Excellent rise/fall time and divergence stability minimizes HAZ for clean cuts.



### Perforating

600 W peak power delivers energy more efficiently, increasing perforating or drilling speeds and reducing HAZ; a solid solution for laser finishing processes on automated packaging lines.



### Thin Film Processing

High peak and average power deliver the perfect laser for quality, precision drilling and cutting applications on a wide variety of thin, sensitive materials.

## Contact Us

synrad.com

### Americas & Asia Pacific

Synrad  
4600 Campus Place  
Mukilteo, WA 98275  
P (425) 349.3500  
F (425) 349.3667  
synrad@synrad.com

### Europe, Middle East, Africa

Novanta Europe GmbH  
Division Synrad Europe  
Parkring 57-59  
D-85748, Garching, Germany  
P +49 (0)89 31707 0  
F +49 (0)89 31707 222  
sales-europe@synrad.com

### China

Synrad China Sales and Service Center  
Unit C, 5/F, Ting Wei Industrial Park  
Liufang Road, Baoan District, Shenzhen  
Guangdong, PRC 518133  
P +86 (755) 8280 5395  
sales-china@synrad.com

### Japan

Novanta Japan Co., Ltd.  
4666 Ikebe-cho Tsuzuki-ku  
Yokohama Kanagawa 224-0053 Japan  
P +81 3 5753 2462  
F +81 3 5753 2467  
sales-japan@synrad.com

# SYNRAD

A Novanta Company